

# Canon

CANON SOLUTIONS AMERICA



CANON SEE IMPOSSIBLE



## OCÉ IMAGE LOGIC® TECHNOLOGY

### Productive, reliable, easy-to-use image processing

Océ Image Logic is a proprietary patented state-of-the-art technology that provides the most productive, reliable, and easy-to-use solution for high quality copying and scanning available on the market. This unique technology consistently turns imperfect originals into high quality copies and scans. Key to its efficiency is that it works automatically inside Océ equipment with little, if any, intervention by the user.

The process of copying and scanning is arguably the most time intensive of all the reproduction tasks in wide format document workflows. Because the user must physically feed the original into the document feed of the scanner, the time taken to scan or copy a document can be significant even when the copy or scan is acceptable the first time. But when the copies are not acceptable the first time, or when the prints are delivered with important information missing, the costs of the reproduction can skyrocket.

Imagine a single document with lines, fine text, photos, renderings, and other shaded areas. Most devices attempt to scan all these features and calculate an average setting with which to print the entire page. Océ digital equipment featuring Océ Image Logic technology can actually evaluate each feature, calculate optimal print settings for each feature and print each feature based on those unique settings. Often, the copies are better than the originals, particularly if those originals are damaged, mutilated, or soiled from age.

Océ Image Logic technology was developed by Océ — a Canon company — with the objective that all originals should be copied or scanned to file with the optimum quality level the first time, without any operator intervention except in the case of special or difficult originals. This not only saves considerable time since the process of copying and scanning is a very time-consuming task. It also assures high quality output even with untrained users. Originals, even if imperfect, such as text, photos and fine drawings are turned into impeccable copies.



## Océ Image Logic technology is unique

Other manufacturers have similar process steps and names for their image processing software; however, Océ Image Logic technology is truly unique because of the dynamic way that it works. Every pixel of every line is analyzed and enhanced in real time from the top to the bottom of the original. Competitive methods of image enhancement usually analyze the first 2" of the original and make all their adjustments based upon that information. In complex technical documents with mixed content, inability to process the entire document can lead to flawed output — and repeated tries to get the scan/copy right.

## How Océ Image Logic technology works

Océ Image Logic technology optimizes the image through a multi-tiered approach:

1. **Scanning** — The original is fed into the scanner and scanned line by line. Each pixel is converted on a scale of 0 to 255 for red, for green, and for blue. This generates a 24-bit RGB image (256 levels per color required 8 bits per color). From here, Océ Image Logic technology takes over.
2. **Converting** — When a monochrome copy is required, the color module converts 24-bit RGB data into a grayscale between zero and 255. This is to ensure that even the lightest colors (for example, yellow) are made visible with grayscales.
3. **Automatic background compensation** — The background is eliminated by adjusting the background levels of all the pixels to the same level of RGB (or gray). As the background level is adjusted continuously over the whole page, this results in a background-free image.
4. **Filtering segmentation and enhancing weak information** — The background-free image is now optimized by advanced filtering to enhance weak information, keep small details open and digitally smooth and soften shaded areas.



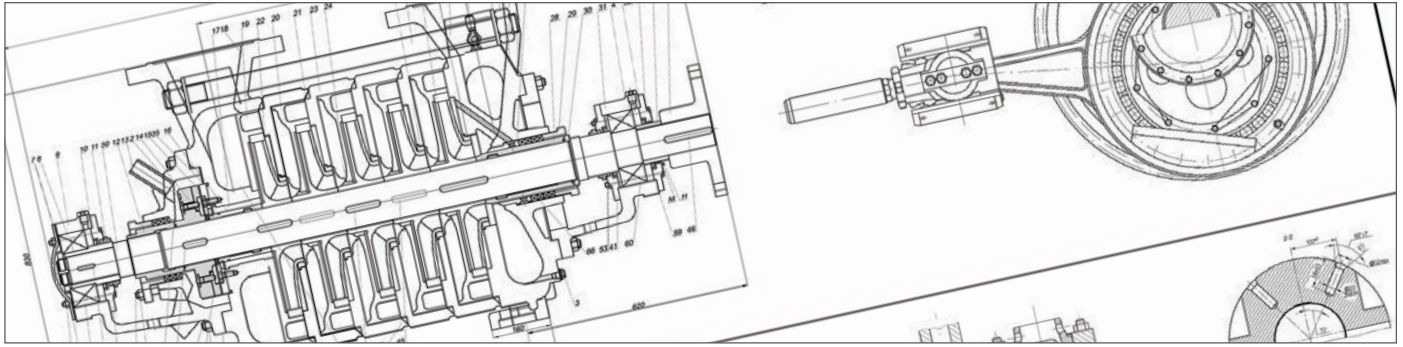

5. **Color management module** — In this module, the RGB values are converted to CMYK values that serve as input for printing. This is done in two stages:

- a. The RGB values are converted to lab values using the scanner profile. Lab is an independent color standard.
- b. The Lab values are converted to values between 0 and 255 for cyan, magenta, yellow, and black. This conversion results in 4 x 8 bits of CMYK data per pixel and takes into account the Océ media profiles for the Océ device.

6. **Halftoning** — This process converts the CMYK images (256 levels per pixel per color) into bitmaps (1 bit per pixel) using the error diffusion technique. In short, the randomly arranged pixels create a visual impression of smooth shades of color, while at the same time ensuring that (weak) lines, solids, and text characters are sharply delineated and filled. The optimized image is now ready for printing.

## Key benefits of Océ Image Logic technology

Océ Image Logic technology has many benefits to an organization's large format document workflow, whether in a walk-up environment or in a central printing operation:

- Saves time and money
- Ensures excellent quality scans and copies with minimal operator intervention
- Reproduces crystal-clear "photos in text" and photos
- Reproduces excellent "mixed" originals and fine/thin lines
- Creates clean scans/copies
- Increases operator productivity
- Reduces wasted media due to flawed copies and repeat work

Océ Image Logic technology is found in Océ ColorWave® and Océ PlotWave® multifunction systems.

# Canon

CANON SOLUTIONS AMERICA

**LARGE FORMAT SOLUTIONS**  
100 PARK BLVD., ITASCA, IL 60143

1-800-714-4427 | 1-630-250-6550  
us.info@csa.canon.com **CSA.CANON.COM**

Canon is a registered trademark of Canon Inc. in the United States and elsewhere. Océ, Océ Image Logic, Océ ColorWave, and Océ PlotWave are registered trademarks of Océ-Technologies B.V. in the United States and elsewhere. All other referenced product names and marks are trademarks of their respective owners and are hereby acknowledged.

© 2016 Canon Solutions America, Inc. All rights reserved.

LFS-51366 DS 3/16 CC1/PDF